

Panel Replacement

B: INSTALLATION

• Overall view

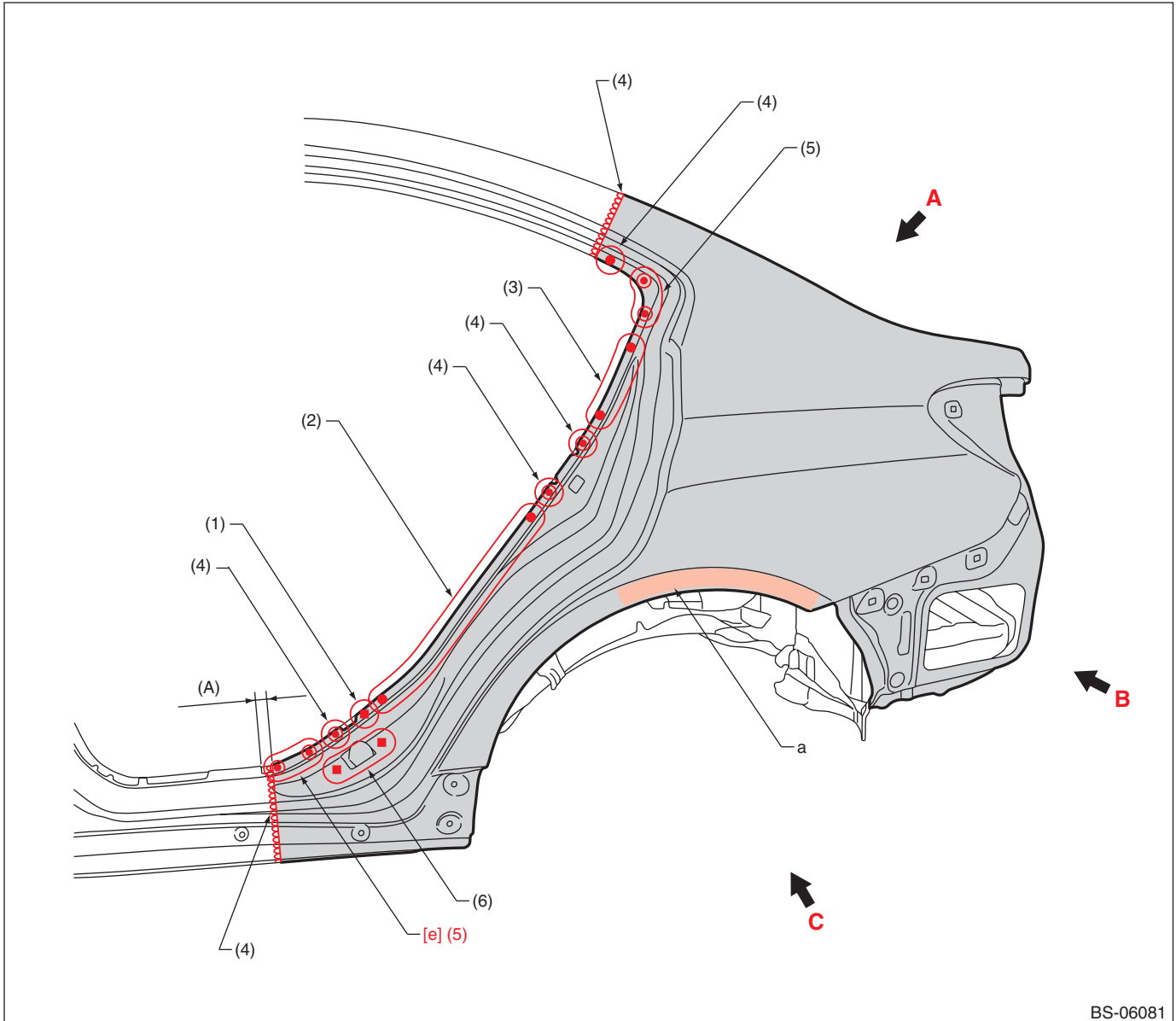

BS-06081

(A) 20 mm (0.79 in)

(1) 1 point (service)

(3) 3 points

(5) 2 points

(2) 8 points

(4) 1 point

(6) 2 points (service)

Note: Apply a panel bonding adhesive to part "a".

[e] Spot welding conditions

Compression: 3.5 kN, Current: 7.5 kA, Welding time: 16 cyc

Panel Replacement

• Views 1

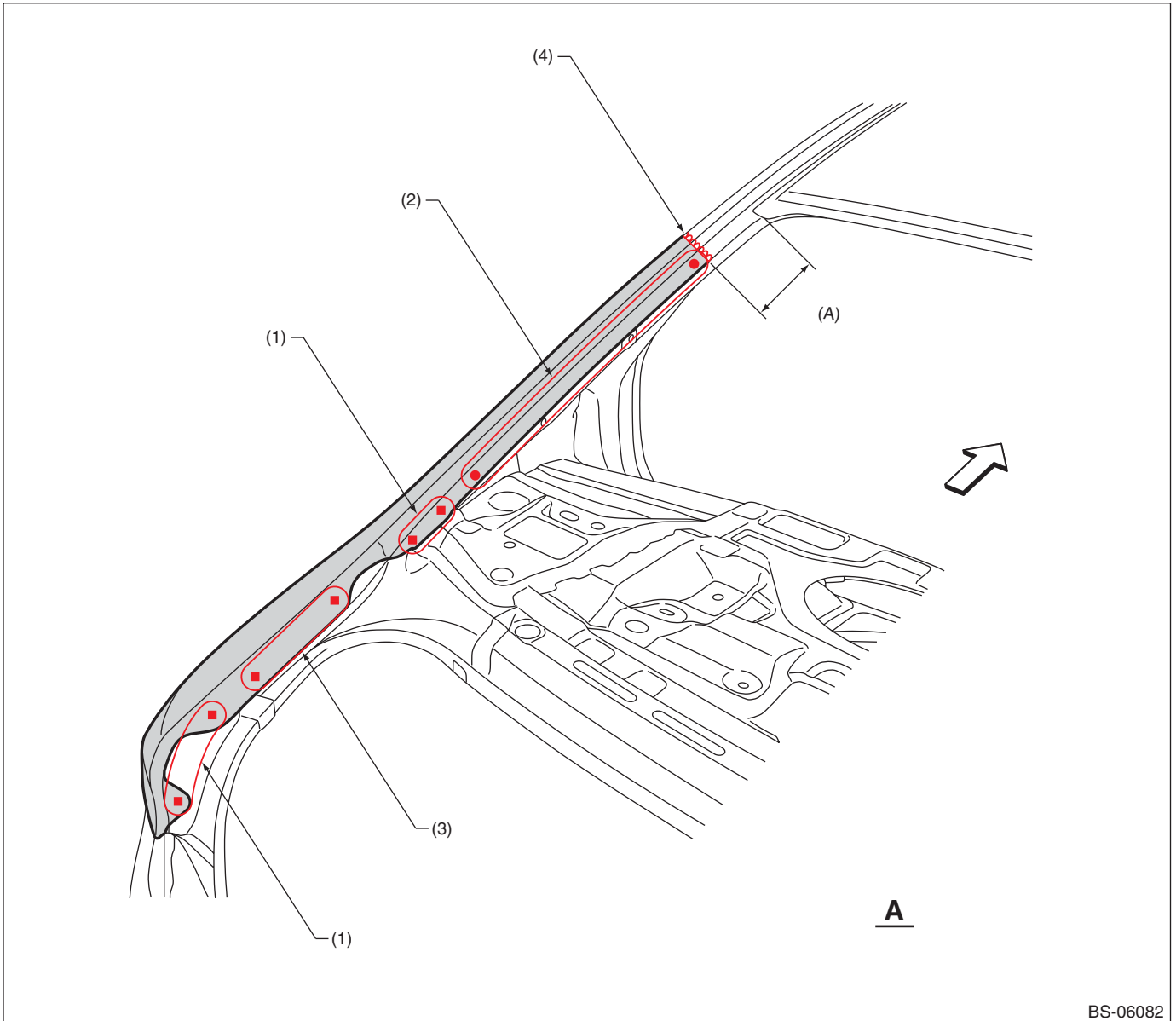

BS-06082

(A) 70 mm (2.76 in)

(1) 2 points (service)

(3) 3 points (service)

(4) 1 point

(2) 7 points

Panel Replacement

• Views 2

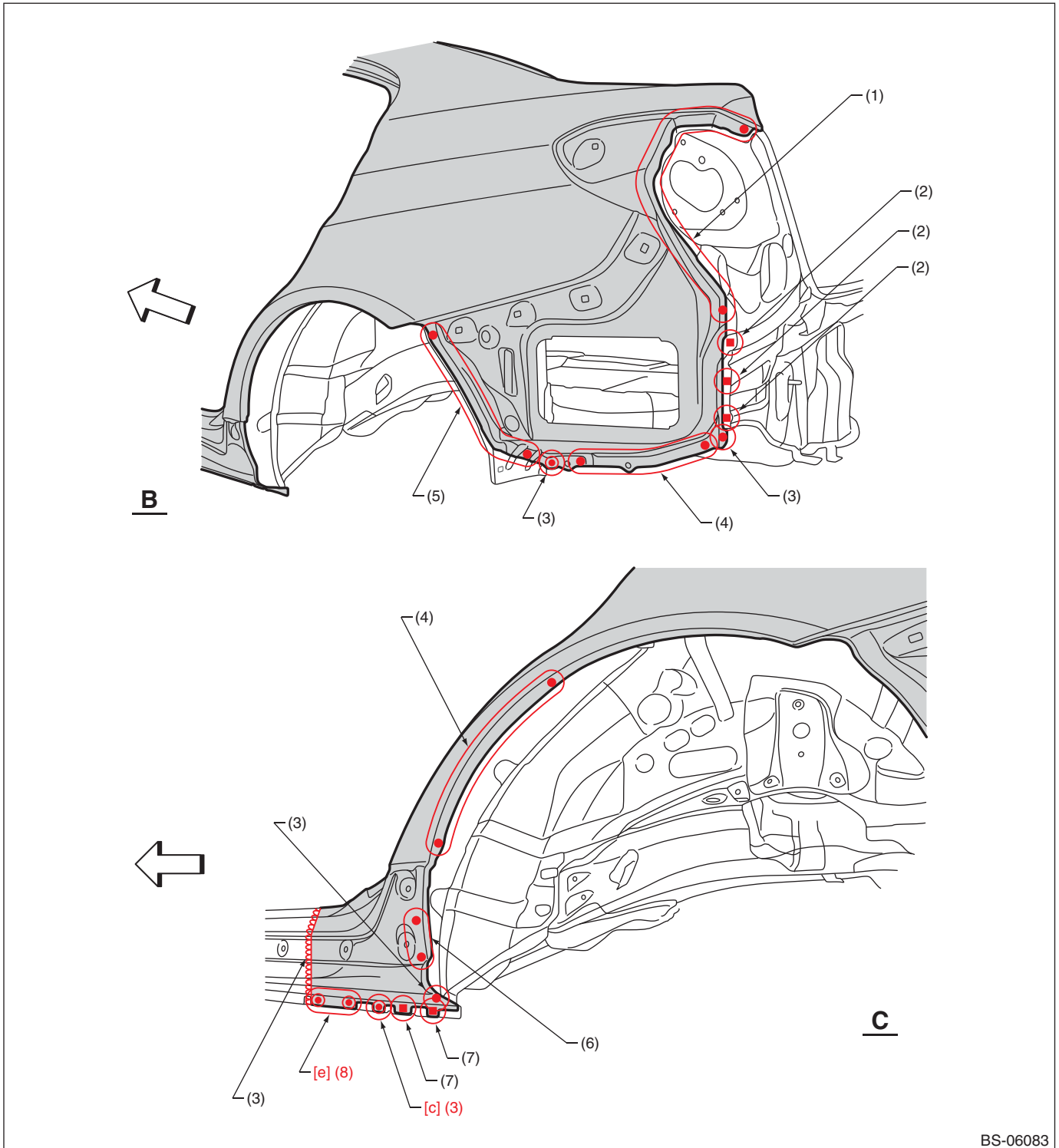

BS-06083

- | | | |
|----------------------------------|--------------|-----------------------|
| (1) 10 points | (4) 5 points | (7) 1 point (service) |
| (2) 1 point (service · matching) | (5) 7 points | (8) 3 points |
| (3) 1 point | (6) 2 points | |

[c] Spot welding conditions	Compression: 3.0 kN, Current: 6.5 kA, Welding time: 25 cyc
[e] Spot welding conditions	Compression: 3.5 kN, Current: 7.5 kA, Welding time: 16 cyc

Panel Replacement

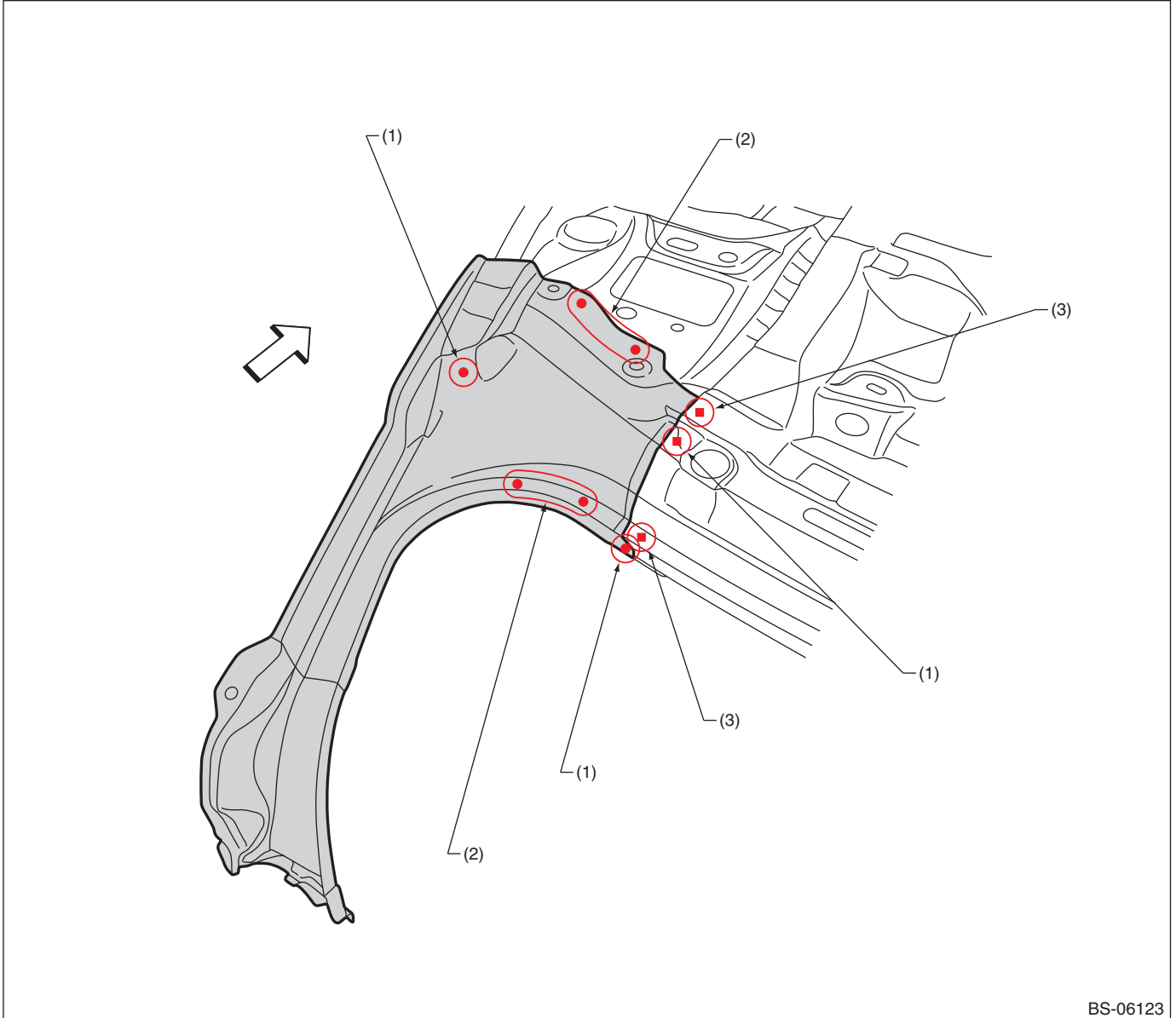

BS-06123

(1) 1 point

(2) 2 points

(3) 1 point (service · matching)